

This catalog covers:  
**TJ045E-□S50**

GRID NO. This grid covers:  
**A-01** TITLE

# PARTS CATALOG

## 2-STROKE ENGINE

### TJ045E

PRODUCT CODE	NOTE
TJ045E-AS50	BRUSH-CUTTER
TJ045E-BS50	

# PARTS CATALOG INTRODUCTION

This parts catalog lists parts and sub-assemblies provided as service parts. When it becomes necessary to replace parts, always use KAWASAKI GENUINE PARTS which have passed strict inspection which guarantees quality and performance.

## 1. HOW TO ORDER PARTS

- When ordering the parts, be sure to use the parts catalog corresponding to the product code. Check the product revision codes on the product and the catalog.  
 Product Code (example) : FA130D-AA00  
 Product Revision Code
- Specify the part code (all digits) exactly as listed in this catalog on your parts order.
- The parts not shown in the illustrations of this catalog are not sold separately; only the complete units or next higher assemblies illustrated are supplied as the service parts.

## 2. EXPLANATION OF PARTS CATALOG FORMAT

Ref. No.	Part No.	Description	Quantity	
			A	B
11004	11004-7001	GASKET-HEAD	2	2
11008	11008-7001	HEAD-COMP-CYLINDER#1	1	1
11008A	11008-7002	HEAD-COMP-CYLINDER#2	1	1
11022	11022-7001	CASE-ROCKER	2	2
11060	11060-7001	GASKET,ROCKER CASE	2	2
11060A	11060-7008	GASKET,CRANKCASE COVER	1	1
11060B	11060-7015	GASKET,BREATHER	1	1
13271	13271-7016	PLATE	1	1
13271A	13271-7016	PLATE	1	1
14690	14690-7001	COVER,BREATHER	1	1
49015	49015-6215	COVER,CRANKCASE	1	1
49109	49109-7002	ELEMENT-BREATHER	1	1
49120	49120-6119	CRANKCASE-COMP	1	1
92033	92033-7003	RING-SNAP	2	2
92043	92043-7001	PIN	6	6
92049	92049-7001	SEAL-OIL	4	4
92049A	92049-7002	SEAL-OIL	1	1
92049B	92049-7004	SEAL-OIL	1	1
92049C	92049-7005	SEAL-OIL	1	1
130	130B0612	BOLT-FLANGED	4	4
130A	130B0640	BOLT-FLANGED	4	4
130B	130T0850	BOLT-FLANGED	17	17
130C	130T0875	BOLT-FLANGED	2	2
172	172G0818	BOLT-STUD	4	4

### 1) Product Code

This code describes the product code covered by this catalog. The product revision code, which is a part of the product code, is omitted.

### 2) Part Group Title

This title is the representative name for the group of parts illustrated on the page.

### 3) Reference Number

The reference numbers are shown on the illustration and the list as the link between them.

## 4) Part Number

This is the key of your parts ordering. Three kinds of part number are used in this catalog.

- Structure 1
- Structure 2
- Standard Hardware Number (for bolts, nuts, washer, or the like)

## 5) Description and Additional Information

The part name, the location, the size, and the serial number as additional information, etc. are described here. Use them to find out and check the part required.

When a part number is changed without change of the product revision code and the changed parts are not interchangeable, the serial number of the product is noted as follows;

- ( FA130 - 100001 ) : Affected units are from beginning of the product of the product code up to and including this serial number.
- ( FA130 - 100002 - ) : Affected units are from this serial number and above.
- ( FA130 - 100002 - FA130 - 110001 ) : Affected units are in this serial number range.

## 6) Quantity

The figure shows quantity of the part required at the indicated position on the illustration and for the specified product revision code.

The asterisk (\*) on this column means the part can be used as the substitute on the product and is supplied until the stock is exhausted.

Note:Some small parts will be supplied by units.

Example: If six (6) bolts are ordered and the minimum quantity per unit is five (5), two (2), units of the bolt will be delivered.

## 7) Product Revision Code

This Code indicates an important change which affects the service parts interchangeability.

## 3. ABBREVIATIONS

#.....Number	FR.....Front	RH.....Right Hand
&.....And	G.....Gram	RPM.....Revolutions Per Minute
(+).....Plus	HEX.....Hexagonal	RR.....Rear
(-).....Minus	ID=.....Inside Diameter	STD.....Standard
2ND.....Second	IN.....Inch	T.....Teeth
3RD.....Third	L=.....Length	T=.....Thickness
4TH.....Fourth	LH.....Left Hand	U/S.....Under Size
A.....Ampere	LWR.....Lower	UPP.....Upper
AR.....As Required	MM.....Millimeter	V.....Volt
ASSY.....Assembly	O/S.....Over Size	W.....Watt
CNT.....Center	OD=.....Outside Diameter	
COMP.....Complete	REF.....Reference	

This catalog covers:

TJ045E- □ S50

GRID NO.

**B-01**

This grid covers:

**PICTORIAL INDEX**

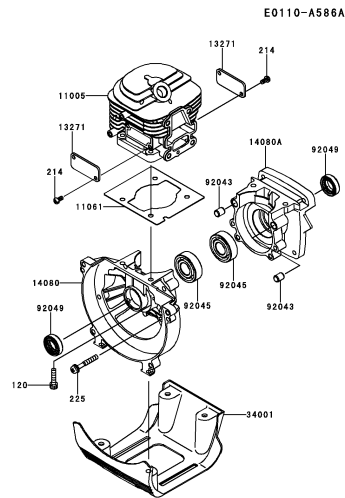

**B-03** CYLINDER/CRANKCASE

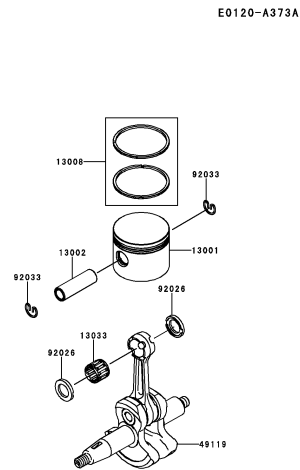

**B-04** PISTON/CRANKSHAFT

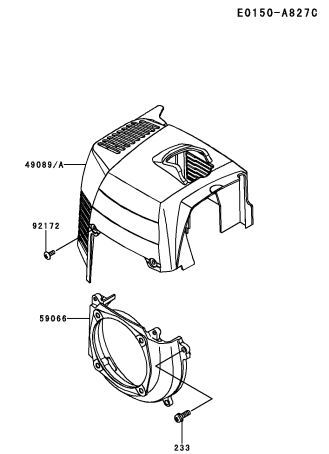

**B-05** COOLING-EQUIPMENT

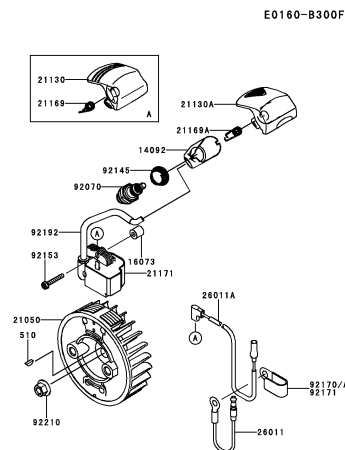

**B-06** ELECTRIC-EQUIPMENT

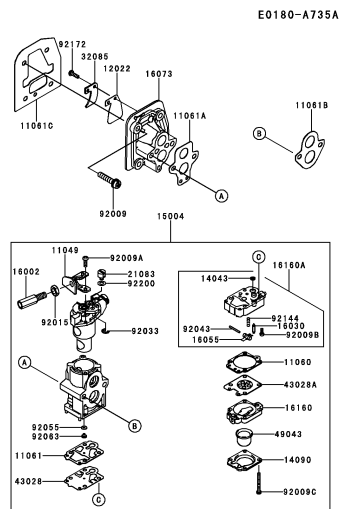

**B-07** CARBURETOR

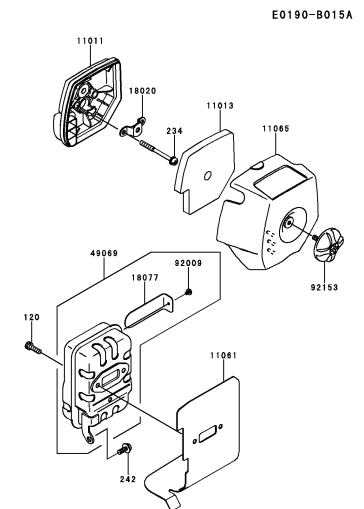

**B-08** AIR-FILTER/MUFFLER

This catalog covers:

TJ045E- □ S50

GRID NO.

**B-02**

This grid covers:

**PICTORIAL INDEX**

E0200-A641A

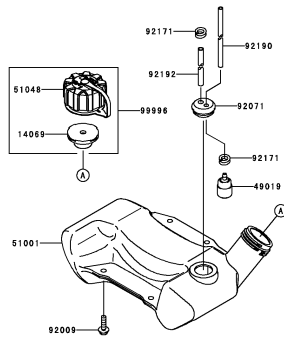

**B-09**

FUEL-TANK/FUEL-VALVE

E0210-A419A

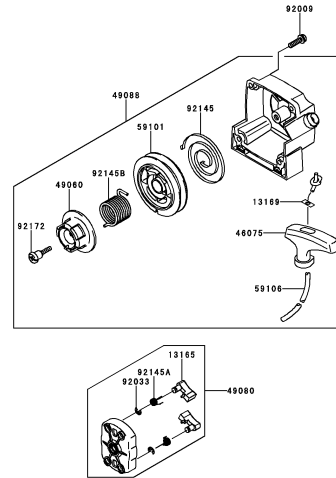

**B-10**

STARTER

E0220-A008D

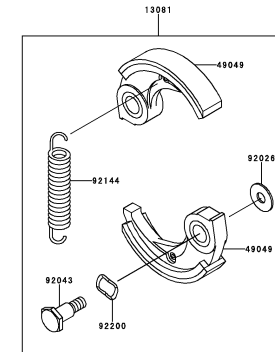

**B-11**

P.T.O-EQUIPMENT

This catalog covers:

TJ045E- □ S50

GRID NO.

C-01

This grid covers:

PICTORIAL INDEX

F0290-B385A

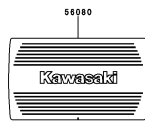
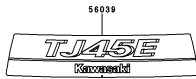

C-03

LABEL

This catalog covers:

TJ045E- □ S50

GRID NO.

**B-03**

This grid covers:

**CYLINDER/CRANKCASE**

E0110-A586A

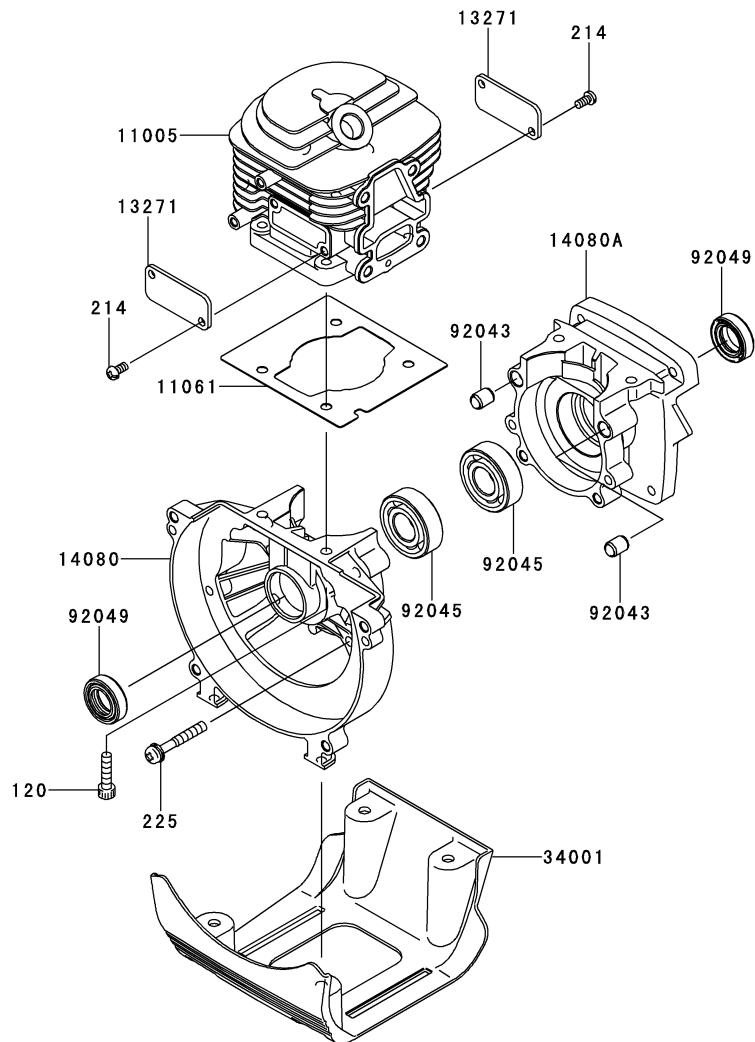

Ref. No.	Part No.	Description	Quantity	
			A	B
11005	11005-2159	CYLINDER-ENGINE	1	1
11061	11061-2173	GASKET,CYLINDER	1	1
13271	13271-2262	PLATE	2	2
14080	14080-2062	CRANKCASE	1	1
14080A	14080-2063	CRANKCASE	1	1
34001	34001-2089	STAND	1	1
92043	92043-1302	PIN	2	2
92045	92045-2279	BEARING-BALL,6202C3	2	2
92049	92049-2259	SEAL-OIL,ISCD-15-25-7-F	2	2
120	120CB0520	BOLT-SOCKET,5X20	4	4
214	214AA0408	SCREW-PAN+,-,4X8	4	4
225	225AA0535	SCREW-PAN-WSP-CROS,5X35	4	4

This catalog covers:

**TJ045E- □ S50**

GRID NO.

**B-04**

This grid covers:

**PISTON/CRANKSHAFT**

E0120-A373A

Ref. No.	Part No.	Description	Quantity	
			A	B
13001	13001-2166	PISTON-ENGINE	1	1
13002	13002-2067	PIN-PISTON	1	1
13008	13008-6067	RING-SET-PISTON	1	1
13033	13033-2063	BEARING-SMALL END	1	1
49119	49119-2231	CRANKSHAFT-ASSY	1	1
92026	92026-2353	SPACER	2	2
92033	92033-2058	RING-SNAP	2	2

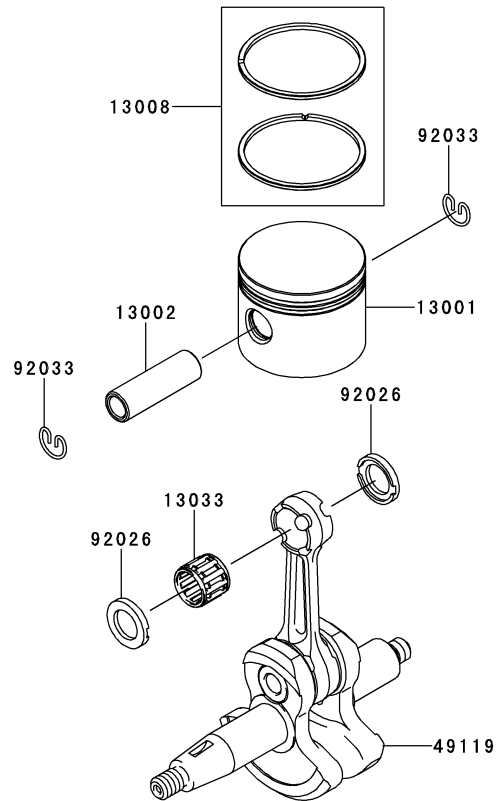

This catalog covers:

**TJ045E-**  **S50**

GRID NO.

**B-05**

This grid covers:

**COOLING-EQUIPMENT**

E0150-A827C

Ref. No.	Part No.	Description	Quantity	
			A	B
49089	49089-2631	SHROUD-ENGINE	1	
49089A	49089-2742	SHROUD-ENGINE		1
59066	59066-2797	HOUSING-FAN	1	1
92172	92172-2060	SCREW,4X10	2	2
233	233AA0516	SCREW-PAN-WP+,-5X16	4	4

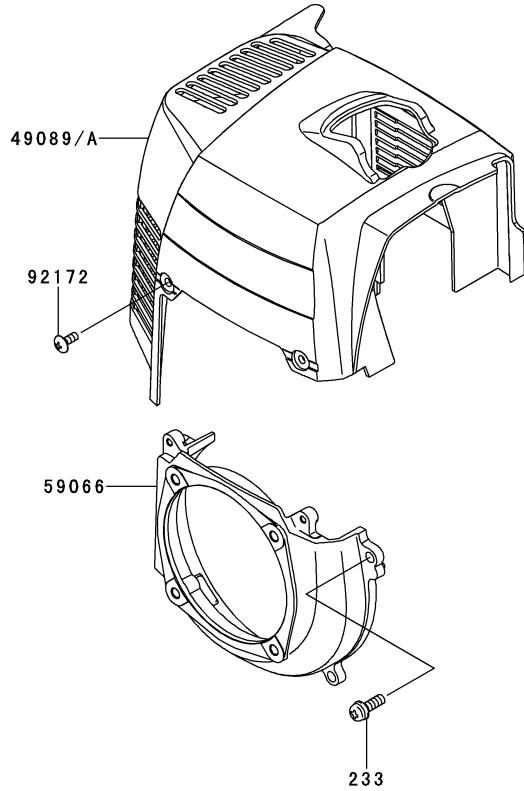



This catalog covers:

TJ045E- □ S50

GRID NO.

**B-06**

This grid covers:

**ELECTRIC-EQUIPMENT**

E0160-B300F

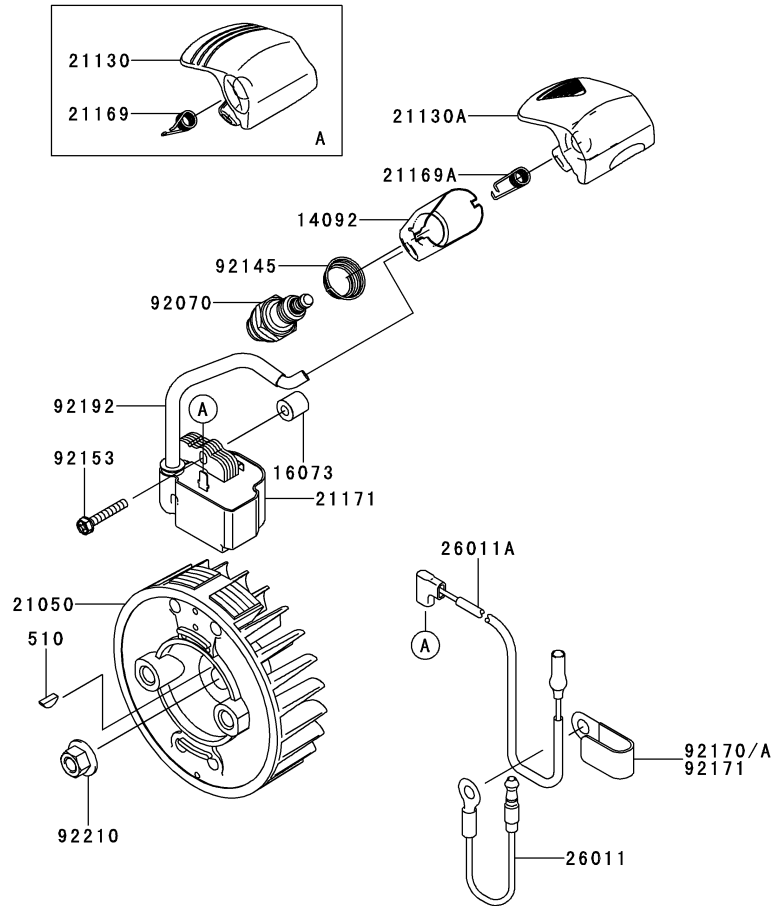

Ref. No.	Part No.	Description	Quantity	
			A	B
14092	14092-2002	COVER		1
16073	16073-2220	INSULATOR	2	2
21050	21050-2313	FLYWHEEL	1	1
21130	21130-2072	CAP-SPARK PLUG	1	
21130A	21130-2080	CAP-SPARK PLUG		1
21169	21169-2051	TERMINAL	1	
21169A	21169-2078	TERMINAL		1
21171	21171-2250	COIL-ASSY-IGNITION	1	1
26011	26011-2113	WIRE-LEAD	1	1
26011A	26011-2361	WIRE-LEAD,L=230	1	1
92070	92070-2107	PLUG-SPARK,BPMR7A(NGK),SOLID	1	1
92145	92145-2193	SPRING		1
92153	92153-2135	BOLT,4X25	2	2
92170	92170-2041	CLAMP	1	
92170A	92170-2041	CLAMP		*
92171	92171-2067	CLAMP		1
92192	92192-2165	TUBE,6X6.6X80	1	1
92210	92210-2101	NUT,M8	1	1
510	510A3100	KEY-WOODRUFF	1	1

This catalog covers:

**TJ045E- □ S50**

GRID NO.

**B-07**

This grid covers:

**CARBURETOR**

E0180-A735A

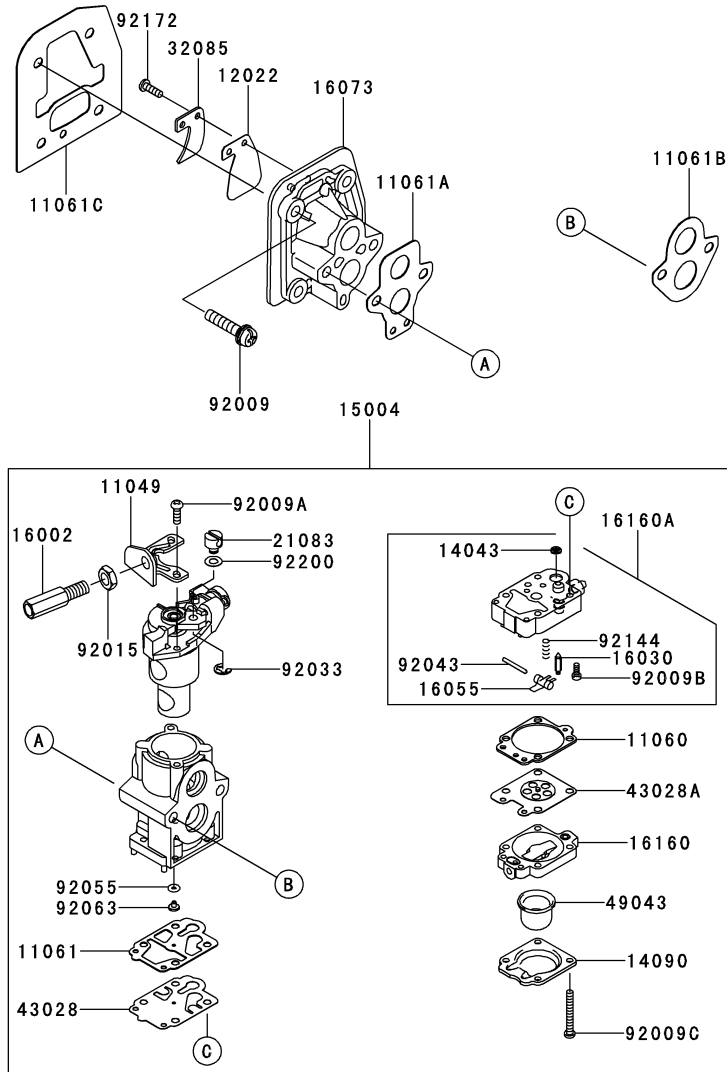

Ref. No.	Part No.	Description	Quantity	
			A	B
11049	11049-2006	BRACKET	1	1
11060	11060-2111	GASKET	1	1
11061	11061-2054	GASKET	1	1
11061A	11061-2175	GASKET,CARBURETOR-INSULATOR	1	1
11061B	11061-2176	GASKET	1	1
11061C	11061-2178	GASKET,CYLINDER-INSULATOR	1	1
12022	12022-2059	VALVE-REED	1	1
14043	14043-2051	FILTER	1	1
14090	14090-2017	COVER,PRIMER PUMP	1	1
15004	15004-2050	CARBURETOR-ASSY	1	1
16002	16002-2056	ADJUSTER-CABLE	1	1
16030	16030-2078	VALVE-FLOAT	1	1
16055	16055-2051	LEVER	1	1
16073	16073-2236	INSULATOR	1	1
16160	16160-2089	BODY	1	1
16160A	16160-2103	BODY	1	1
21083	21083-2073	ARM	1	1
32085	32085-2105	STOPPER	1	1
43028	43028-2067	DIAPHRAGM	1	1
43028A	43028-2096	DIAPHRAGM	1	1
49043	49043-2067	PUMP-PRIMING	1	1
92009	92009-2235	SCREW,5X25	4	4
92009A	92009-2277	SCREW	2	2
92009B	92009-2336	SCREW	1	1
92009C	92009-2337	SCREW	4	4
92015	92015-2145	NUT	1	1
92033	92033-2078	RING-SNAP	1	1
92043	92043-2094	PIN	1	1
92055	92055-2147	RING-O	1	1
92063	92063-2483	JET-MAIN,#40	1	1
92144	92144-2308	SPRING	1	1
92172	92172-2091	SCREW,3X12	1	1
92200	92200-2074	WASHER	1	1

This catalog covers:

**TJ045E- □ S50**

GRID NO.

**B-08**

This grid covers:

**AIR-FILTER/MUFFLER**

E0190-B015A

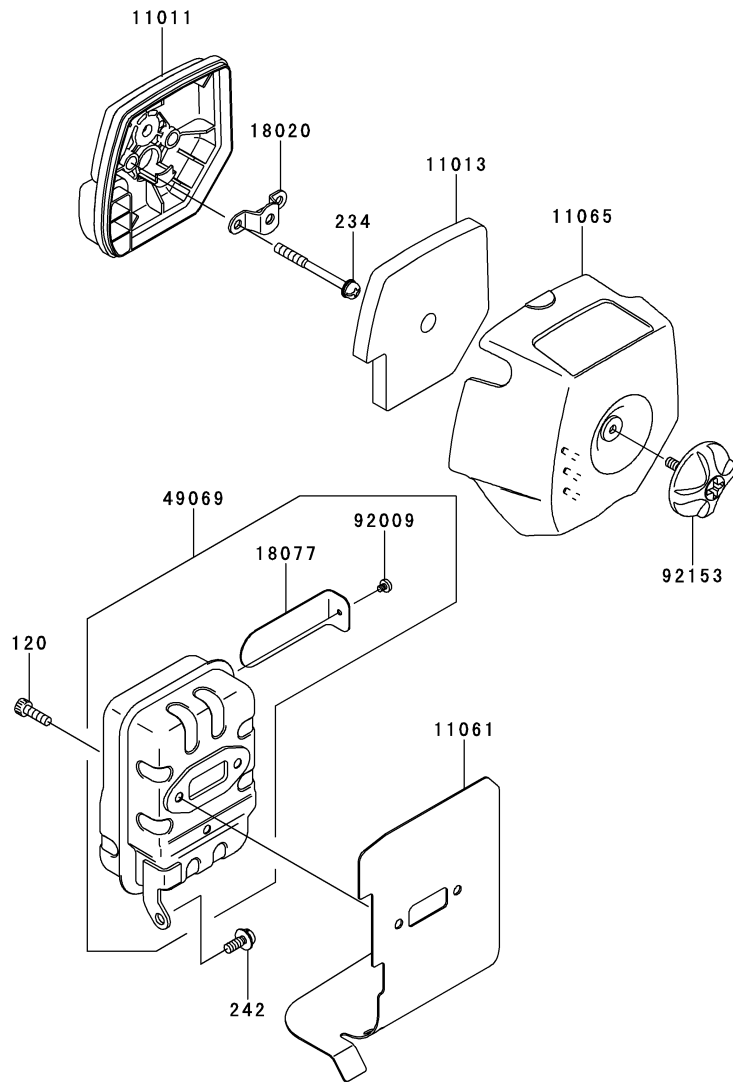

Ref. No.	Part No.	Description	Quantity	
			A	B
11011	11011-2362	CASE-AIR FILTER	1	1
11013	11013-2226	ELEMENT-AIR FILTER	1	1
11061	11061-2174	GASKET,MUFFLER	1	1
11065	11065-2123	CAP	1	1
18020	18020-2091	BAFFLE	1	1
18077	18077-2137	ARRESTER-SPARK	1	1
49069	49069-2430	MUFFLER-ASSY	1	1
92009	92009-2411	SCREW	1	1
92153	92153-2128	BOLT	1	1
120	120CB0516	BOLT-SOCKET,5X16	2	2
234	234AA0555	SCREW-PAN-WSP+,-,5X55	2	2
242	242AA0514	SCREW-PAN-WSP+,-,5X14	1	1

This catalog covers:  
**TJ045E-**  **S50**

GRID NO.

**B-09**

This grid covers:

**FUEL-TANK/FUEL-VALVE**

E0200-A641A

Ref. No.	Part No.	Description	Quantity	
			A	B
14069	14069-2088	BREATHER	1	1
49019	49019-2114	FILTER-FUEL	1	1
51001	51001-2324	TANK-COMP-FUEL	1	1
51048	51048-2083	CAP-ASSY-TANK	1	1
92009	92009-2383	SCREW,5X20	4	4
92071	92071-2142	GROMMET,FUEL TANK	1	1
92171	92171-2073	CLAMP	2	2
92190	92190-2157	TUBE,3X5X200	1	1
92192	92192-2149	TUBE,3X6X105	1	1
99996	99996-6089	CAP-TANK & BREATHER,ASSY	1	1

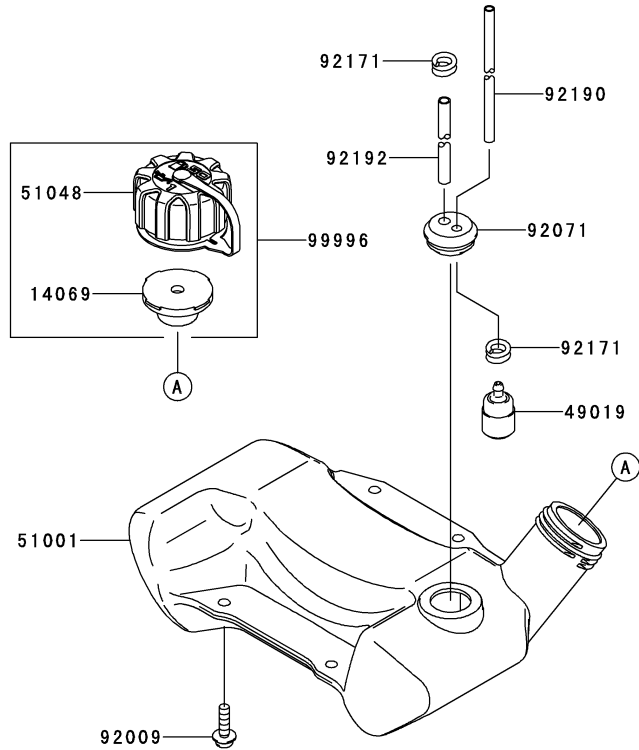

This catalog covers:

**TJ045E- □ S50**

GRID NO.

**B-10**

This grid covers:

**STARTER**

E0210-A419A

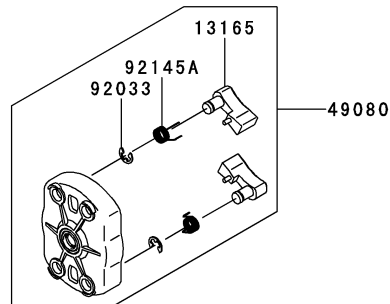
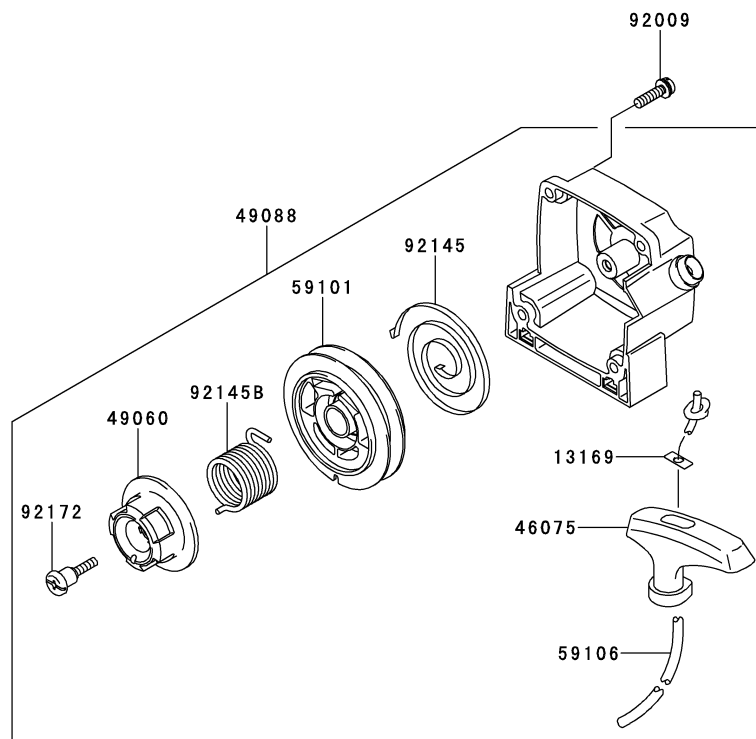

Ref. No.	Part No.	Description	Quantity	
			A	B
13165	13165-2107	PAWL	2	2
13169	13169-2386	PLATE,RECOIL STARTER	1	1
46075	46075-2129	GRIP,RECOIL STARTER	1	1
49060	49060-2065	CAM,STARTER-RECOIL	1	1
49080	49080-2205	PULLEY-STARTING	1	1
49088	49088-2559	STARTER-RECOIL	1	1
59101	59101-2120	REEL,STARTER-RECOIL	1	1
59106	59106-2064	ROPE,3.8X950	1	1
92009	92009-2249	SCREW,5X20	4	4
92033	92033-2010	RING-SNAP	2	2
92145	92145-2112	SPRING,SPIRAL	1	1
92145A	92145-2148	SPRING	2	2
92145B	92145-2150	SPRING	1	1
92172	92172-2100	SCREW	1	1

This catalog covers:

**TJ045E- □ S50**

GRID NO.

**B-11**

This grid covers:

**P.T.O-EQUIPMENT**

E0220-A008D

Ref. No.	Part No.	Description	Quantity	
			A	B
13081	13081-2220	CLUTCH-ASSY	1	1
49049	49049-2075	SHOE-CLUTCH	2	2
92026	92026-2125	WASHER	2	2
92043	92043-2210	PIN,CLUTCH	2	2
92144	92144-2390	SPRING	1	1
92200	92200-2064	WASHER,SPRING,10.5X14.5X0.3	2	2

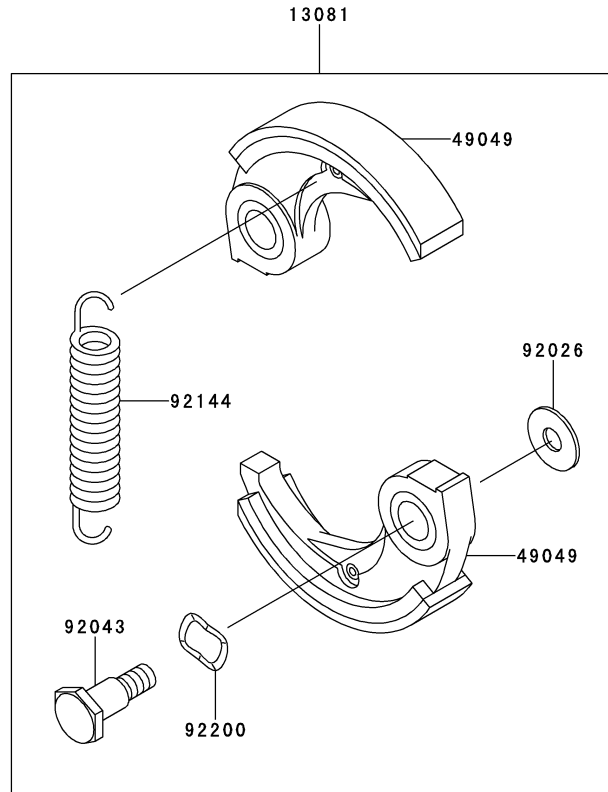

This catalog covers:

**TJ045E- □ S50**

GRID NO.

**C-03**

This grid covers:

**LABEL**

F0290-B385A

Ref. No.	Part No.	Description	Quantity	
			A	B
56039	56039-2954	LABEL-PRODUCT	1	1
56070	56070-2020	LABEL-WARNING	1	1
56080	56080-2413	LABEL-BRAND	1	1

56039



56070



56080



This catalog covers:

**TJ045E- □ S50**

GRID NO.

**H-09**

This grid covers:

---

## PART NAME INDEX

AIR-FILTER/MUFFLER.....	B-08
CARBURETOR.....	B-07
COOLING-EQUIPMENT.....	B-05
CYLINDER/CRANKCASE.....	B-03
ELECTRIC-EQUIPMENT.....	B-06
FUEL-TANK/FUEL-VALVE.....	B-09
LABEL.....	C-03
P.T.O-EQUIPMENT.....	B-11
PISTON/CRANKSHAFT.....	B-04
STARTER.....	B-10



This catalog covers:

**TJ045E- □ S50**

GRID NO.

**H-10**

This grid covers:

**NUMERICAL PARTS INDEX**

Part No.	Grid No.	Part No.	Grid No.	Part No.	Grid No.	Part No.	Grid No.	Part No.	Grid No.
11005-2159.....	B-03	49049-2075.....	B-11	99996-6089.....	B-09				
11011-2362.....	B-08	49060-2065.....	B-10						
11013-2226.....	B-08	49069-2430.....	B-08						
11049-2006.....	B-07	49080-2205.....	B-10						
11060-2111.....	B-07	49088-2559.....	B-10						
11061-2054.....	B-07	49089-2631.....	B-05						
11061-2173.....	B-03	49089-2742.....	B-05						
11061-2174.....	B-08	49119-2231.....	B-04						
11061-2175.....	B-07	51001-2324.....	B-09						
11061-2176.....	B-07	51048-2083.....	B-09						
11061-2178.....	B-07	510A3100.....	B-06						
11065-2123.....	B-08	56039-2954.....	C-03						
12022-2059.....	B-07	56070-2020.....	C-03						
120CB0516.....	B-08	56080-2413.....	C-03						
120CB0520.....	B-03	59066-2797.....	B-05						
13001-2166.....	B-04	59101-2120.....	B-10						
13002-2067.....	B-04	59106-2064.....	B-10						
13008-6067.....	B-04	92009-2235.....	B-07						
13033-2063.....	B-04	92009-2249.....	B-10						
13081-2220.....	B-11	92009-2277.....	B-07						
13165-2107.....	B-10	92009-2336.....	B-07						
13169-2386.....	B-10	92009-2337.....	B-07						
13271-2262.....	B-03	92009-2383.....	B-09						
14043-2051.....	B-07	92009-2411.....	B-08						
14069-2088.....	B-09	92015-2145.....	B-07						
14080-2062.....	B-03	92026-2125.....	B-11						
14080-2063.....	B-03	92026-2353.....	B-04						
14090-2017.....	B-07	92033-2010.....	B-10						
14092-2002.....	B-06	92033-2058.....	B-04						
15004-2050.....	B-07	92033-2078.....	B-07						
16002-2056.....	B-07	92043-1302.....	B-03						
16030-2078.....	B-07	92043-2094.....	B-07						
16055-2051.....	B-07	92043-2210.....	B-11						
16073-2220.....	B-06	92045-2279.....	B-03						
16073-2236.....	B-07	92049-2259.....	B-03						
16160-2089.....	B-07	92055-2147.....	B-07						
16160-2103.....	B-07	92063-2483.....	B-07						
18020-2091.....	B-08	92070-2107.....	B-06						
18077-2137.....	B-08	92071-2142.....	B-09						
21050-2313.....	B-06	92144-2308.....	B-07						
21083-2073.....	B-07	92144-2390.....	B-11						
21130-2072.....	B-06	92145-2112.....	B-10						
21130-2080.....	B-06	92145-2148.....	B-10						
21169-2051.....	B-06	92145-2150.....	B-10						
21169-2078.....	B-06	92145-2193.....	B-06						
21171-2250.....	B-06	92153-2128.....	B-08						
214AA0408.....	B-03	92153-2135.....	B-06						
225AA0535.....	B-03	92170-2041.....	B-06						
233AA0516.....	B-05	92170-2041.....	B-06						
234AA0555.....	B-08	92171-2067.....	B-06						
242AA0514.....	B-08	92171-2073.....	B-09						
26011-2113.....	B-06	92172-2060.....	B-05						
26011-2361.....	B-06	92172-2091.....	B-07						
32085-2105.....	B-07	92172-2100.....	B-10						
34001-2089.....	B-03	92190-2157.....	B-09						
43028-2067.....	B-07	92192-2149.....	B-09						
43028-2096.....	B-07	92192-2165.....	B-06						
46075-2129.....	B-10	92200-2064.....	B-11						
49019-2114.....	B-09	92200-2074.....	B-07						
49043-2067.....	B-07	92210-2101.....	B-06						